

Code No: 126DY

JAWAHARLAL NEHRU TECHNOLOGICAL UNIVERSITY HYDERABAD

B. Tech III Year II Semester Examinations, February - 2023

STEEL STRUCTURES DESIGN AND DRAWING

(Civil Engineering)

Time: 3 hours

Max. Marks: 75

Note: i) Question paper consists of Part A, Part B.

ii) Part A is compulsory, which carries 25 marks. In Part A, Answer all questions.

iii) In Part B, Answer any one question from each unit. Each question carries 10 marks and may have a, b as sub questions.

PART - A**(25 Marks)**

- 1.a) What are the different types of limit states? [2]
- b) What are the various modes of failures of bolted connections? [3]
- c) What are the parameters influencing the buckling class of cross-sections? [2]
- d) Explain the various factors effecting the strength of a compression member? [3]
- e) Define Plastic moment capacity of a section. [2]
- f) Distinguish between web buckling and crippling. [3]
- g) What are the components of a resisting force developed at any bolt of a bracket connection? [2]
- h) Explain the salient features of a Stiffened seated connection. [3]
- i) What is the main function of a bearing stiffener? [2]
- j) Explain the optimum depth of a Plate girder. [3]

PART - B**(50 Marks)**

- 2.a) Draw the stress-strain curve for Structural steel and explain the salient features.
- b) Explain the load transfer mechanism of a bolted double cover butt joint. [5+5]

OR

3. Design a double cover butt-joint to connect two structural steel plates with cross-sectional dimensions $200 \text{ mm} \times 16 \text{ mm}$ and $200 \text{ mm} \times 12 \text{ mm}$ subjected to tensile force of 450 kN. Also, find the efficiency of the joint. Use bolts of grade 4.6. [10]
 4. Design a battened column consisting of two channels back-to-back, height 7.2 m, subjected to a factored axial load of 1500 kN. The column is restrained against rotation and translation at one end and not restrained against rotation at the other end. [10]
- OR**
5. Design a slab base for a column ISHB 350 @ 724 N/m subjected to a factored load of 1250 kN. The column is supported on M25 grade concrete pedestal. [10]

6. Design a simply supported beam of span 6 m is subjected to a factored uniformly distributed load of 30 kN/m over the entire span in addition to a factored concentrated load of 150 kN at its mid-span. Assume the beam is laterally supported. [10]

OR

7. Determine the bending strength of a laterally supported beam section ISMB 300 @ 442 N/m subjected to shear force of 225 kN. [10]

8. An ISMB 350 @ 524 N/m is to be connected to a column ISHB 400 @ 774 N/m. The beam transfers a factored end reaction of 350 kN. Design a stiffened seated connection using bolts of grade 4.6. [10]

OR

9. Design a bracket type of bolted connection shown in figure. Thickness of the bracket plate is 12 mm. [10]

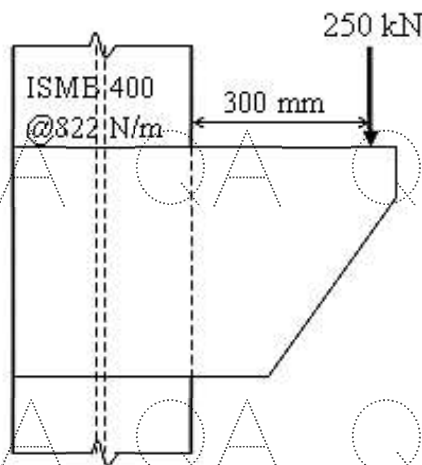

10. A simply supported plate girder of span 16 m has Top flange: 300 mm × 22 mm, Bottom flange: 250 mm × 22 mm and web: 900 mm × 10 mm. The plate girder is subjected to a concentrated load of 400 kN at its mid-span. Design the bearing stiffener. Adopt the length of bearing is 200 mm. [10]

OR

11. Design the web splice for a plate girder section subjected to bending moment of 5000 kNm and shear force of 1250 kN. The section of the plate girder consists of each flange of 550 mm × 16 mm, and web plate 2500 mm × 16 mm. [10]

---ooOoo---